

P

EASA
european architecture students assembly

HOSPITALITY

d

FREDERICA
denmark 2017

s

U

finding the framework

status: may 2017





EASA er

et netværk af arkitektstuderende fra hele kontinentet;

årlig begivenhed for 600 studerende fra 50 lande;

2 ugers af intensivt arbejde på omkring 35 projekter;

grundlagt i 1981.

easa 2017 mission statement



Missjonen for EASA 2017 er at have en positiv indvirkning på Fredericias byliv og bymiljø og at finde innovative løsninger for livskvalitet af Fredericias borgere.

EASA 2017 skal være leverandør af nyskabende arkitektur med en unik mulighed for de studerende og lokale beboere til at arbejde sammen om innovative projekter, som vil blive en katalysator for forandring i byen.

1981 Liverpool, England: Starting up the EASA Experience

1982 Delft, Netherlands: Architecture of an Uncertain Future

1983 Lisbon, Portugal: Social Spaces

**1984 AARHUS, DENMARK:
TURNING POINT IN
ARCHITECTURE**

1985 Athens, Greece: Interpretation and Action in the City

1986 Torino, Italy: Architettura Latenti

1987 Helsinki-Putikko, Finland: Architecture and Nature

1988 Berlin, Germany: The Dimension Between

1989 Marseille, France: Heritage et Créativité

1990 Karlskrona, Sweden: Exploration

1991 Verkhoturie and Kolomna, USSR: Regeneration (This assembly was held at two sites)

1992 UrgUp, Turkiye: Vision 2000 Environment

1993 Sandwick, Scotland: The Isle

1994 Liège, Belgium: Consommer l'Inconsumable

1995 Zamosć, Poland: Beyond the Borders

1996 Clermont-l'Hérault, France: Dream Builders!

**1997 THE TRAIN, SCANDINAVIA:
ADVANCING ARCHITECTURE**

1998 Valletta, Malta: Living on the Edge

1999 Kavala, Greece: Osmosis

2000 Antwerp and Rotterdam, Belgium/Netherlands: Dis-Similarities

2001 Gökceada, Turkey: No Theme

2002 Vis, Croatia: Senses

**2003 FRILAND, DENMARK:
SUSTAINABLE LIVING**

2004 Roubaix, France: Metropolitan - Micropolitain,

2005 Bergün, Switzerland: Trans, Transit, Transition.

2006 Budapest, Hungary: Common Places

2007 Eleusina, Greece: City Index

2008 Dublin-Letterfrack, Ireland: Adaptation

2009 Brescia, Italy: supermARCHet

2010 Manchester, UK: Identity

2011 Cadiz, Spain: deCOASTruction

2012 Helsinki, Finland: Wastelands

2013 Žužemberk, Slovenia: Reaction

2014 Veliko Tarnovo, Bulgaria: Symbioza

2015 Valletta, Malta: Links

2016 Lithuania, Nida: Not Yet Decided

**2017 FREDERICIA, DENMARK:
HOSPITALITY. FINDING THE
FRAMEWORK**



temaet

For det kommende år har EASA vedtaget et tema “Hospitality. Finding the framework”.

Temaet resonerer med Fredericias historie og de nuværende udfordringer i byen.

Temaet indebærer et tæt samarbejde med Fredericia Kommune og lokale beboere med øje for løsningsdrevne tiltag i lokalmiljøet.



placering



indkvartering

arbejdsområde

kommunikation om projektet

introduktion udstilling

vi planlægger at holde easa
udstillingen i rådhusforhallen
i juni for at fortælle borgere
mere om easa projektet



final
udstilling

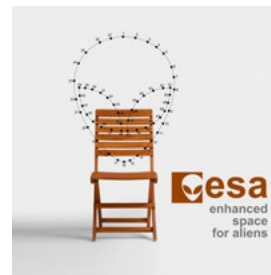
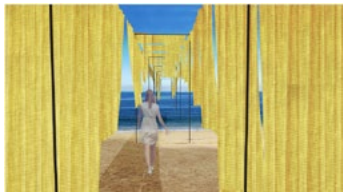
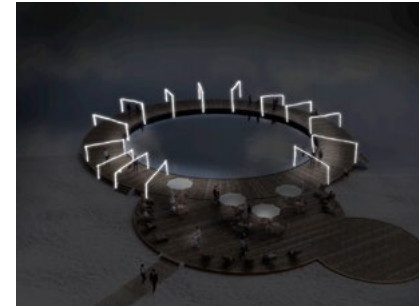

esa
enhanced
space
for aliens

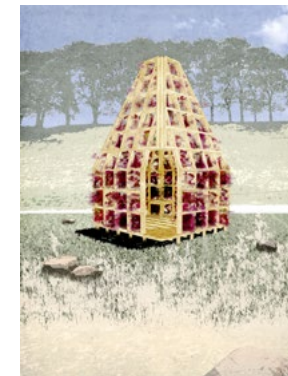

final report



Previous EASA Final reports.



Previous EASA Final reports.



Sam Patterson from EASA Scotland gives EASA Final Report to a partner

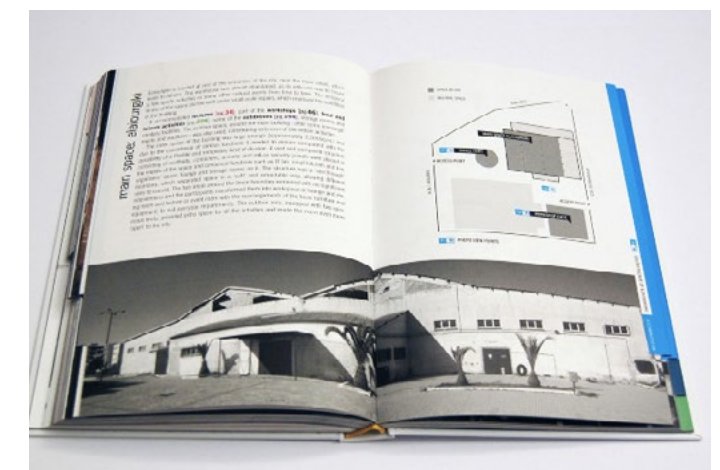

Previous EASA Final reports.

dokumentarfilm

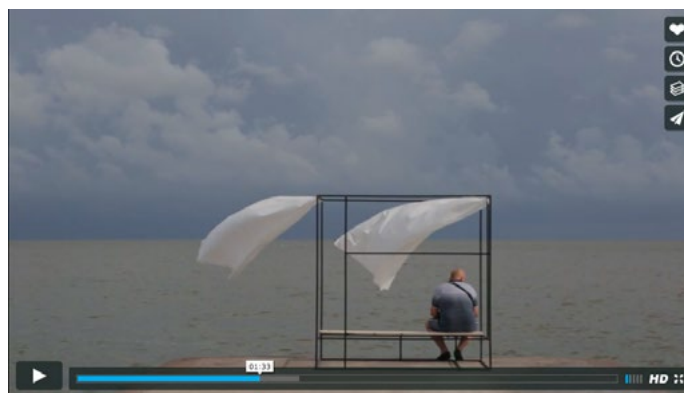

Here and below: snapshots from previous EASA documentaries



program

July 21st - August 6th

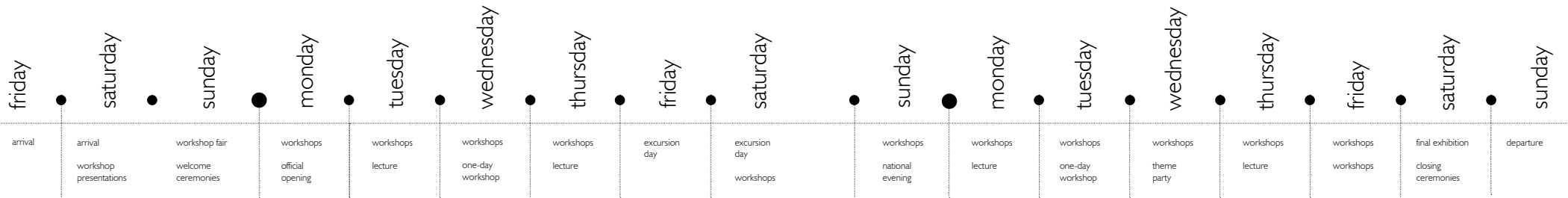

At the workshop presentations, participants learn about all the workshops to choose the one that they like the best

At the workshop fair participants choose the workshop they want to take part of for the following two weeks.

Normal EASA day starts at about 9am with breakfast which is followed by workshops through the day. Often in the evening there is a lecture or an other extra activity.

National Evening is a consistent highlight of every EASA where each nation will prepare a stall to share the flavours and experience of their home country.

EASA ends with the workshop exhibition when EASA participants, local community and visitors are able to walk around the city and see all the projects done for the two weeks period.

**35 forventes
realiseret**

placering:

-  konstruktion
-  teoretiske/håndværk/media

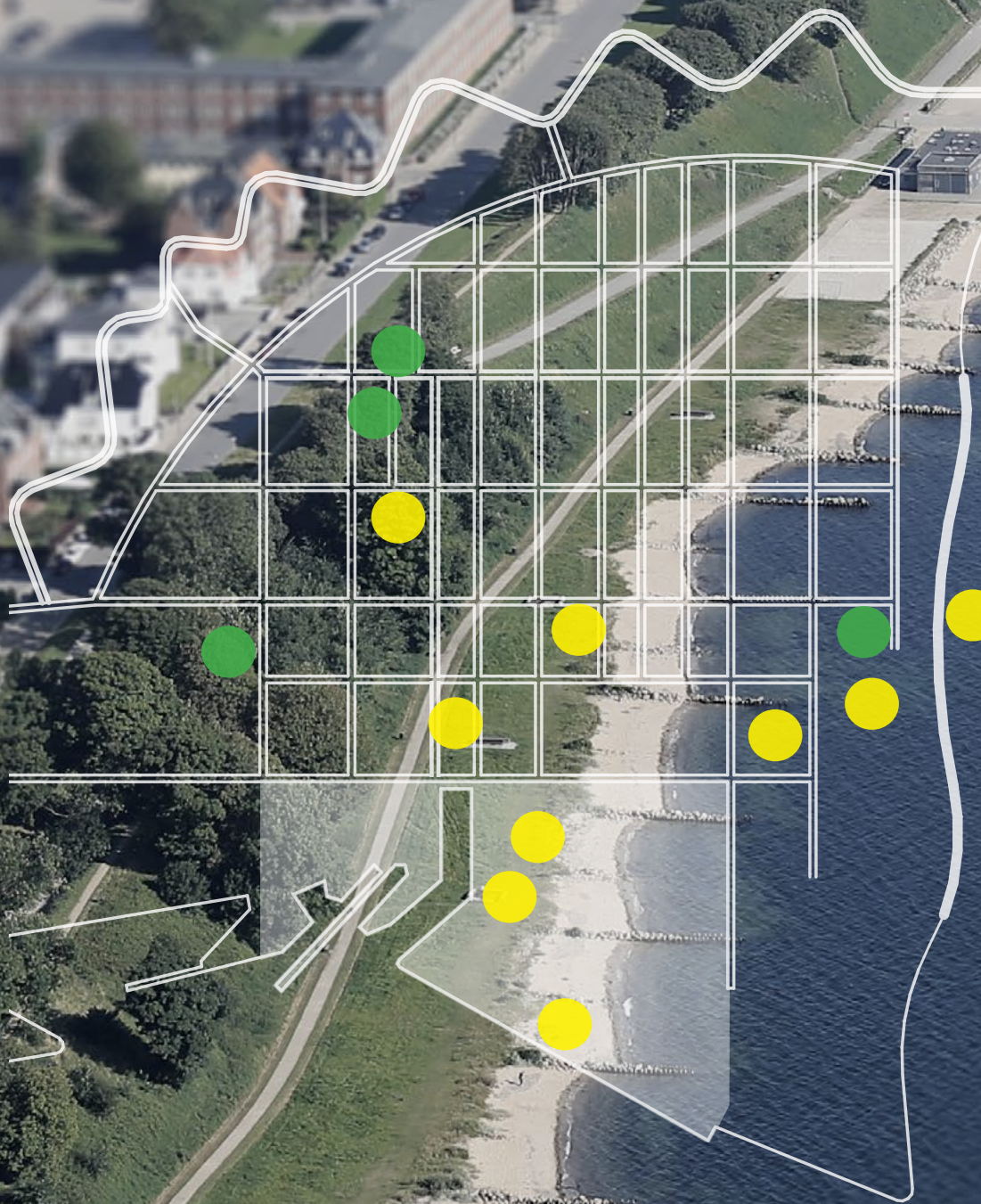

fordeling af projekter 2017

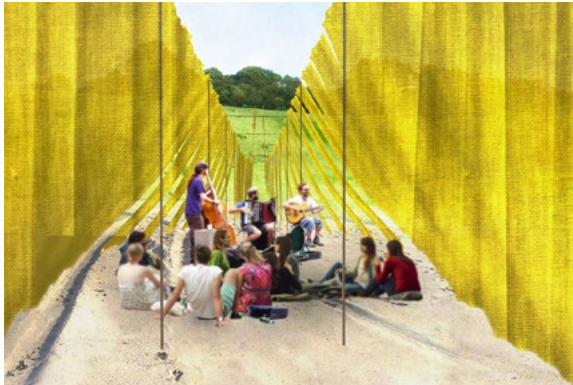

design/construction/technology

19 projekter



håndværk

7 projekter



theoretical/performance

6 projekter



media

3 projekter

INTERofCOURSE

oversigt an nteractive installation of 500 PVC pipes, created to provoke people and let them find the limit of their comfort zone.

kategori construction

material wood

byggetilladelser kræves ikke

budget 48 000 DKK

varighed midlertidig

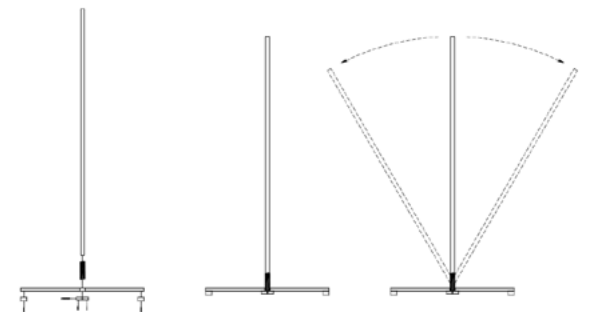
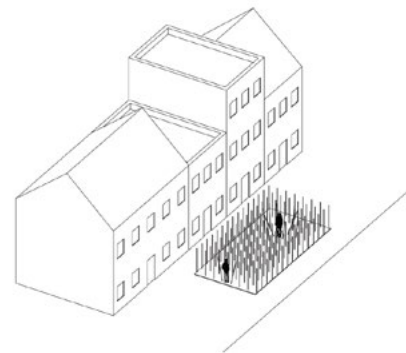
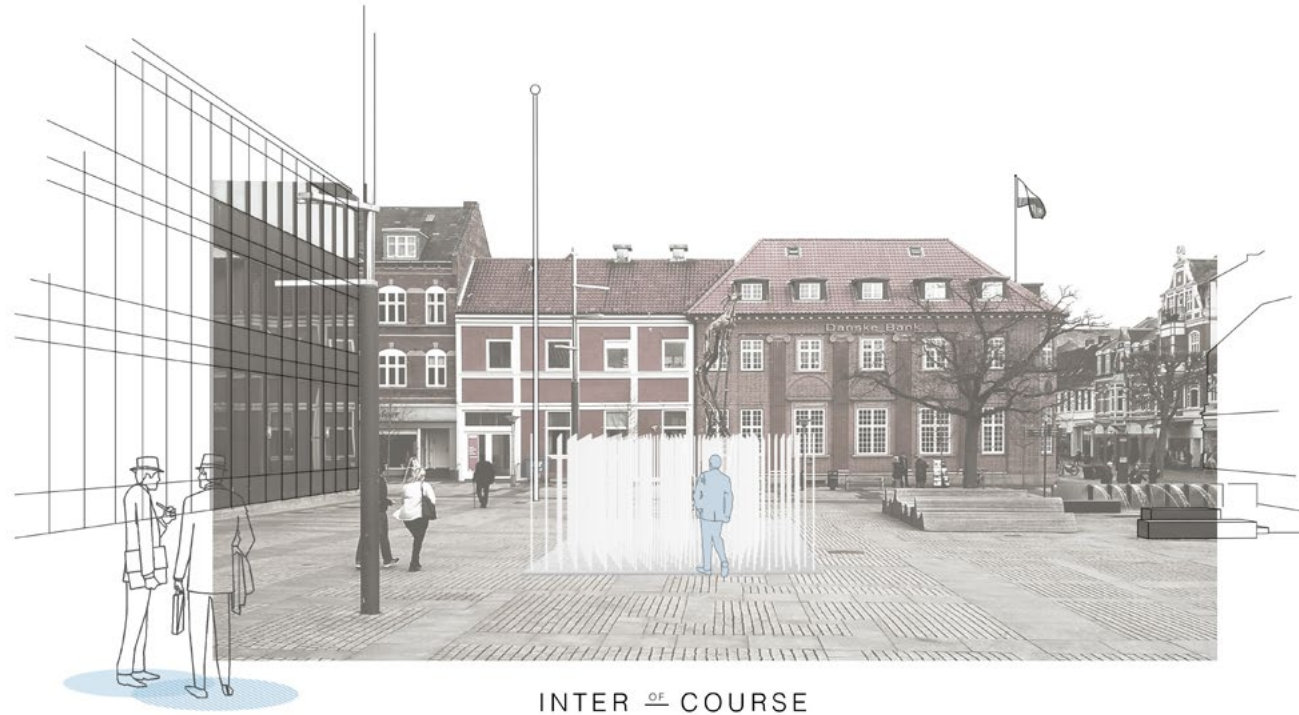

a city with many sounds

oversigt sound installation with
pre-recorded sounds of
Fredericia

kategori media

material wood

budget 10 000 DKK

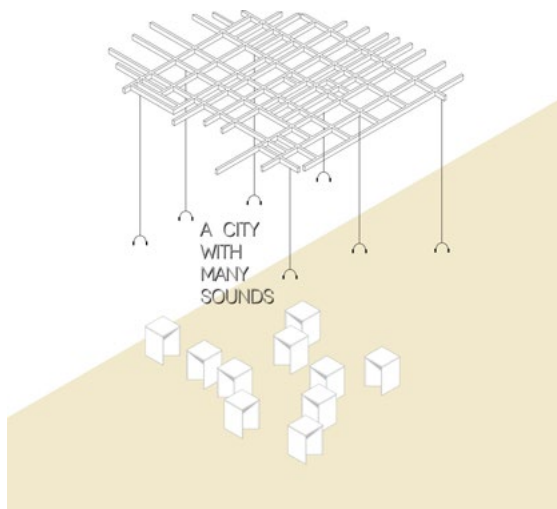

neptune

oversigt The workshop is simple we are proposing to create a cooker, smoker, fishermen socialising shelter.

The aim is to create a rapport with the local fishermen and create a social environment for our participants to learn the preparation of catching and cooking fish.

kategori design&construction/community

material metal

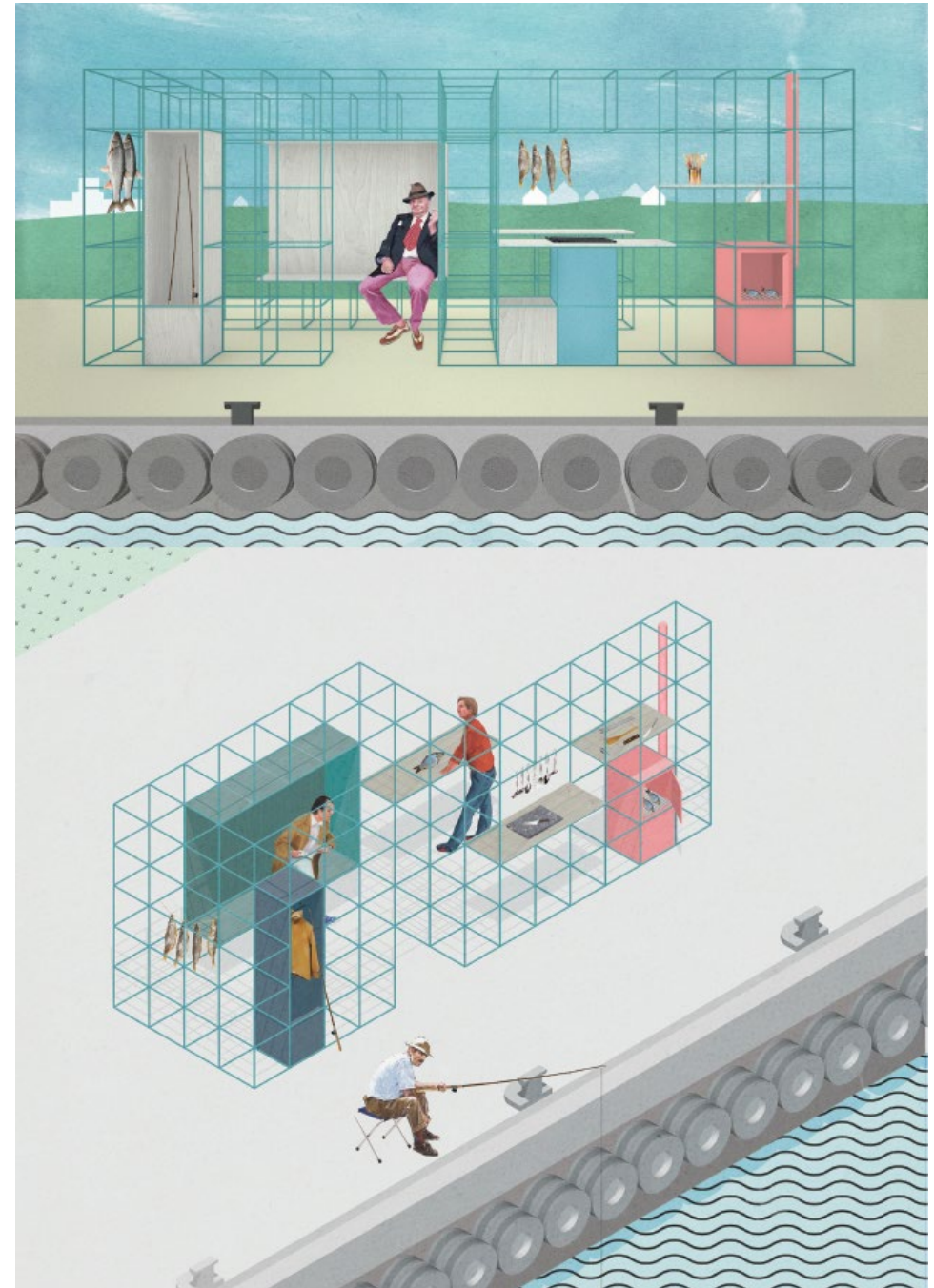

imprint

oversigt A screen printing workshop. The workshop starts with building some of the equipment, continues with good ideas and ends with printing the designs together with locals. All the equipment stays in Ungdommenshuset after.

kategori crafts
 material prints

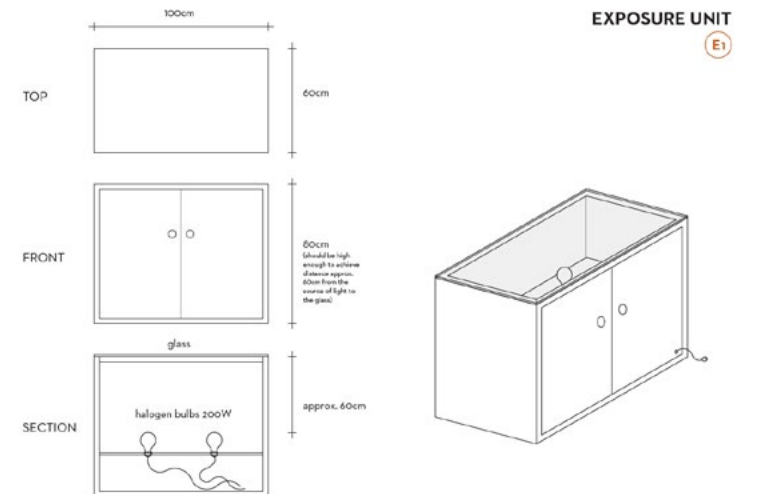
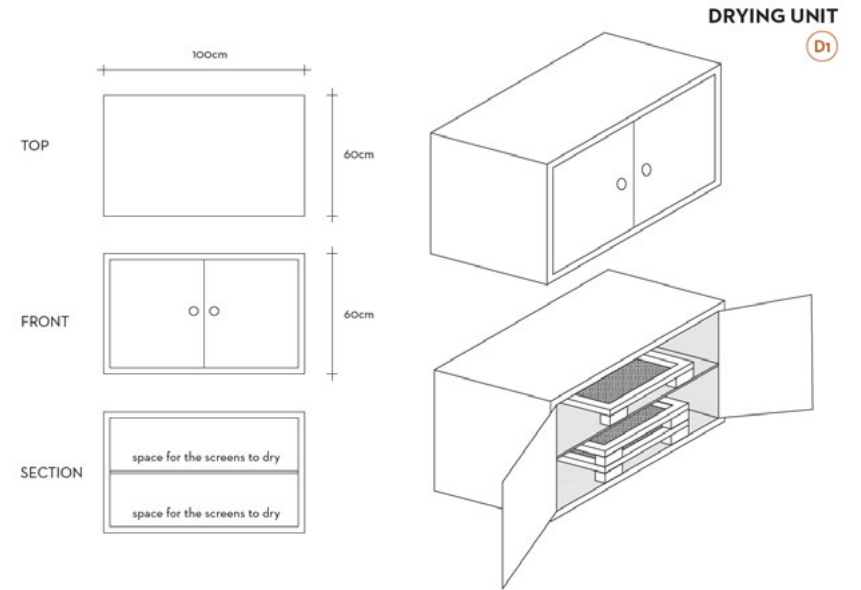
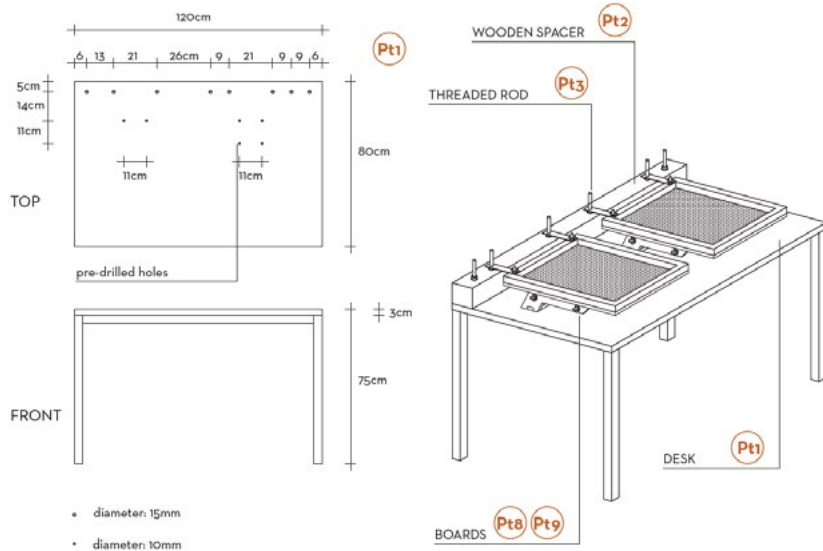

BioSPHERE

oversigt The workshop aims to revive the sensitivity towards nature and provide with basic knowledge of plants and their environments by touching, planting and experimenting while creating a self sustainable indoor forest.

kategori design&construction

material Plants

byggetilladelser kræves ikke

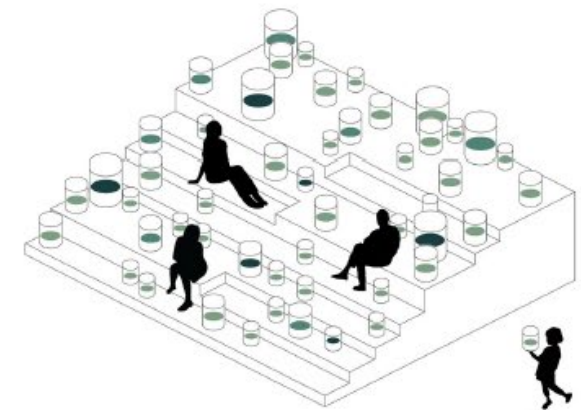
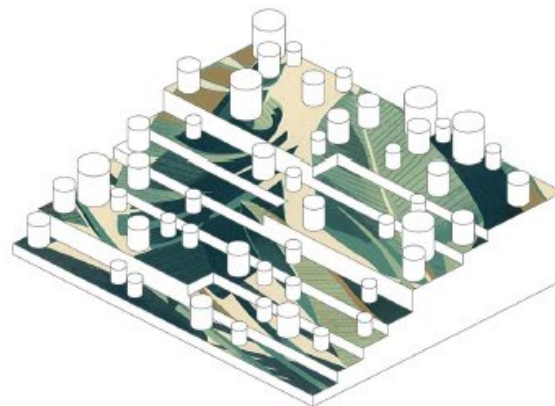
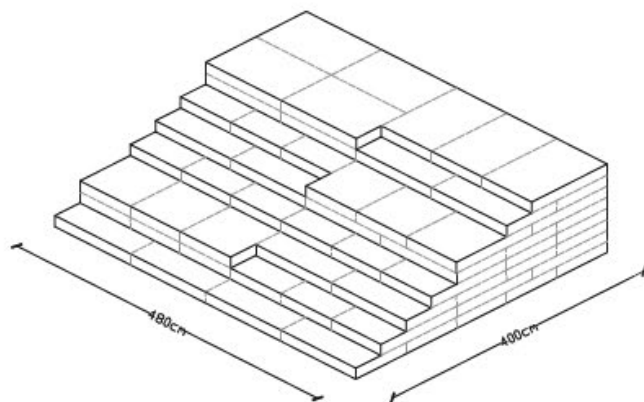
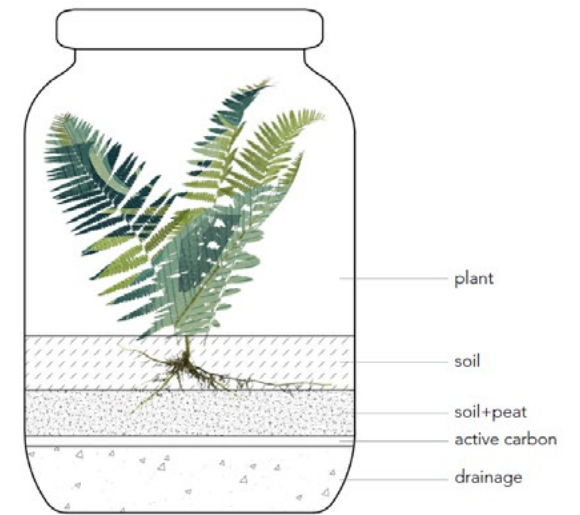

babel

oversigt the open workshop, which will offer creators the chance to construct their own ideas on a defined site without long planning processes creating a structure that serves EASA and Fredericia.

kategori design&construction

material wood

byggetilladelser kræves ikke



Colour

skabe fremtiden sammen

New International Cross-societal Artists Residency & Gallery.

colour

oversigt a travelling art space

kategori construction

material wood

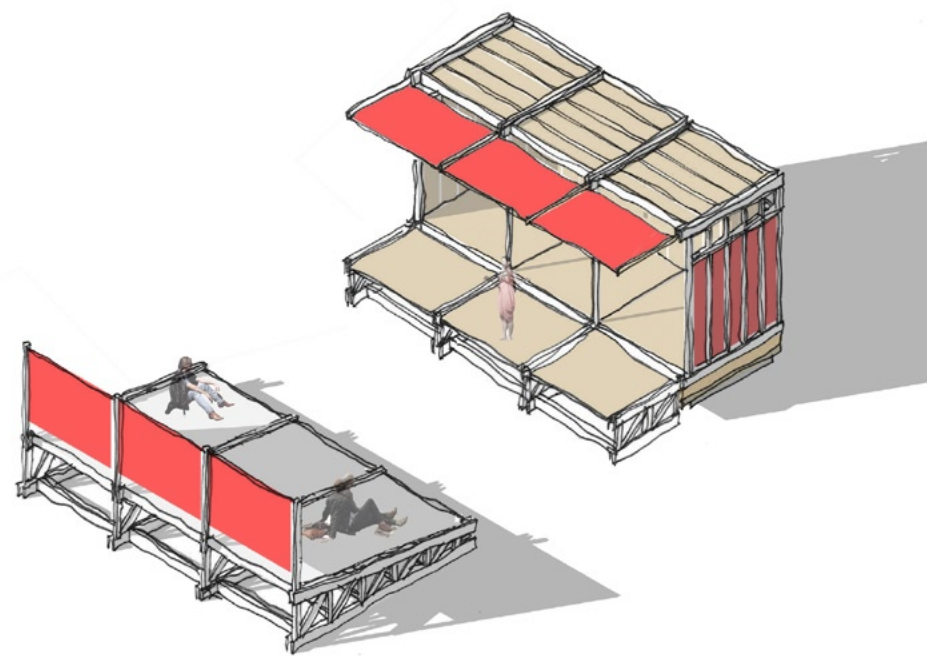
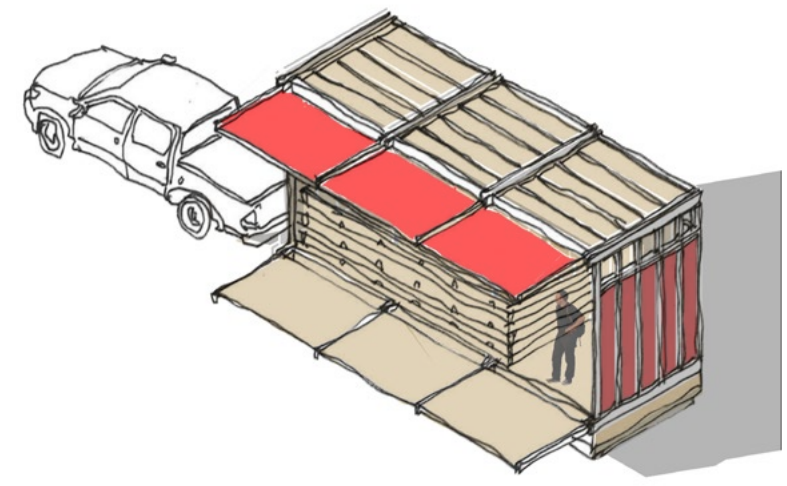

current



oversigt The concrete pavilion serves as protection from and celebration of Fredericia's continuous rainfall. Water will not only flow away from the structure but through.

kategori design&construction
material wood

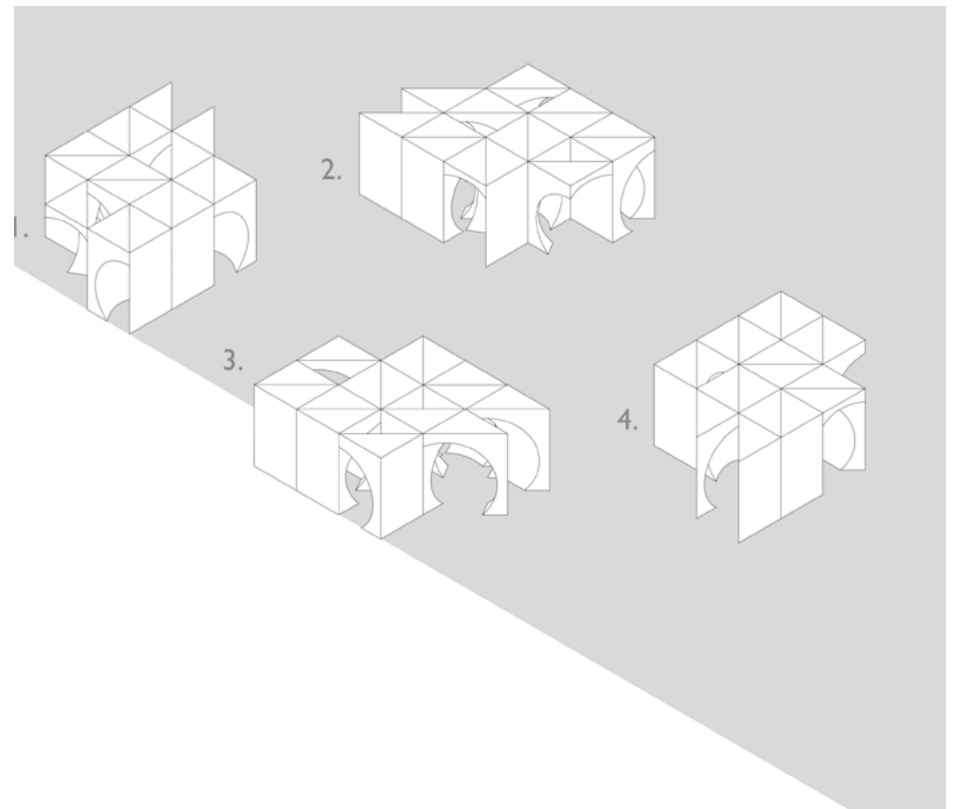

The People's Collection

oversigt "A bench, a stool or legs crossed on the floor,
Our street plays host to these things and more,
But a landscape awaits which bulges and twists,
This workshop sure is not to be missed.

kategori design&construction

material wood

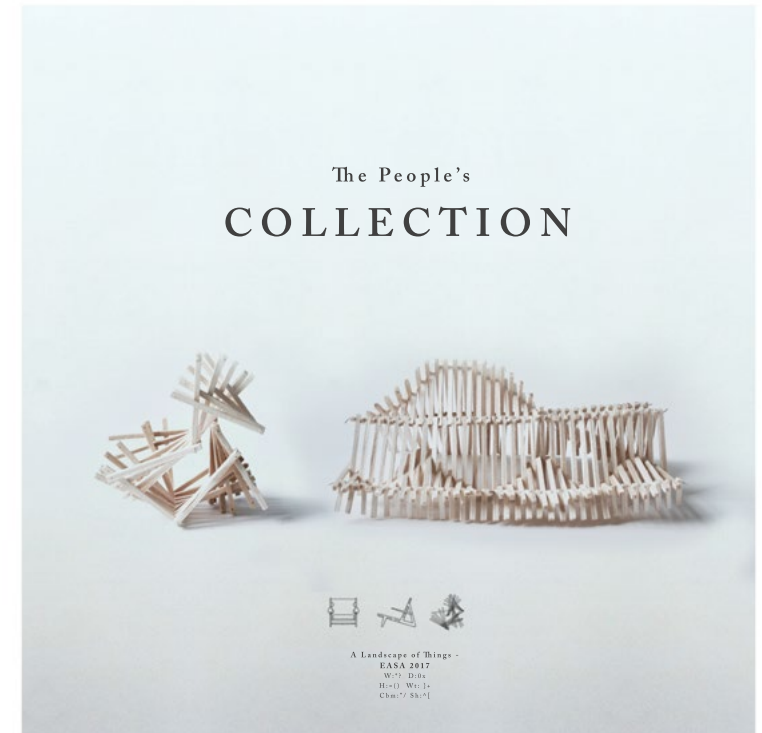

Penelope

oversigt Penelope is expectant, sitting at the corner of the harbour, looking around her with many eyes. Between the water and the city she waits, as beacon to those departing and to those arriving, as a wife expecting the return of her loved ones.

kategori design&construction

material wood

byggetilladelser kræves ikke

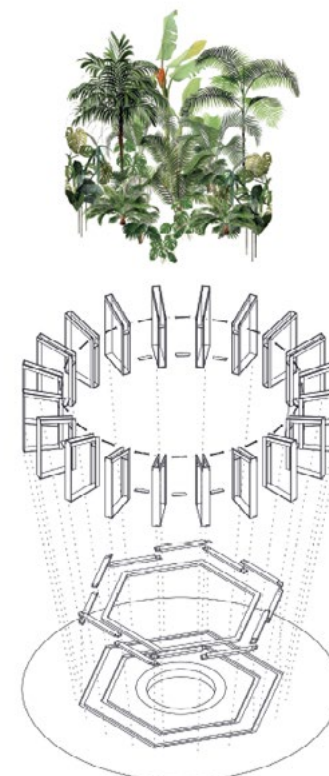

Frick

oversigt a square pavilion in the overall shape, with a “composition” of different structures, related to the urban context inside. The bricks are made on site out of soil.

kategori design&construction

material soil bricks

byggetilladelser kræves

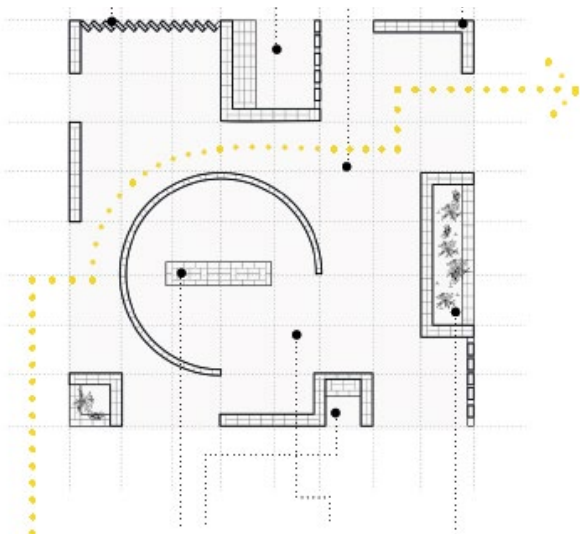

Hi

oversigt a system consisting of a row of light tubes,
and an easy-to-use control panel.
The system enables people to express emo-
tions by a simple compositon of colours and
frequencies,

kategori design&construction

material wood

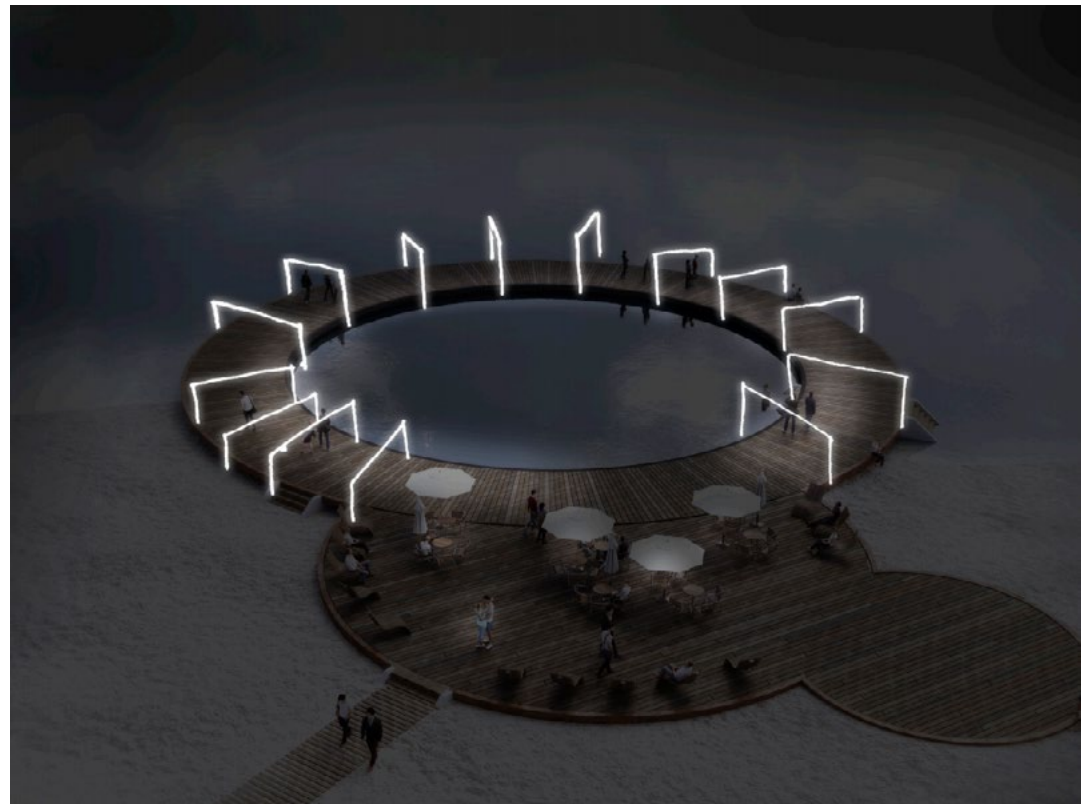

Uline

oversigt Uline - aims to question the meaning of walls - which are the physical response to the concept of border - by emptying its central part and making it walkable. Our aim is to change its meaning from a barrier to a connection line

kategori design&construction

material metal

byggetilladelser kræves ikke

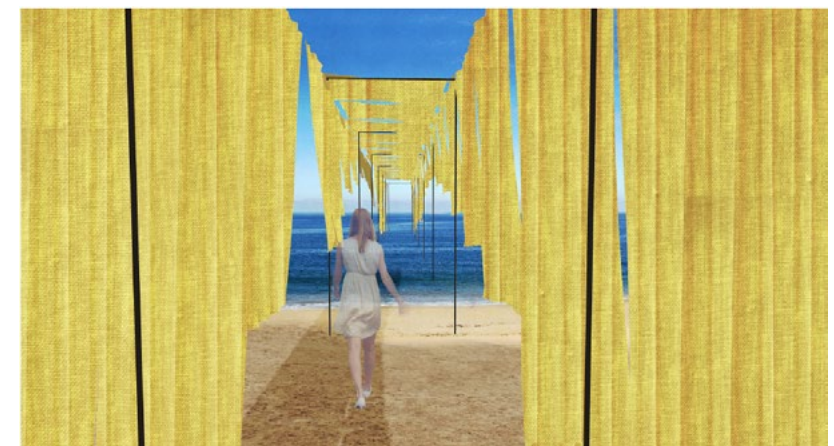
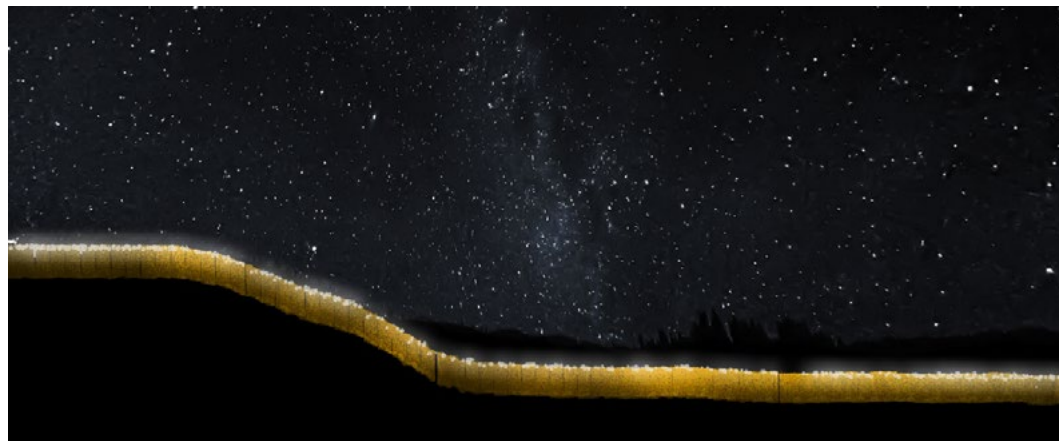
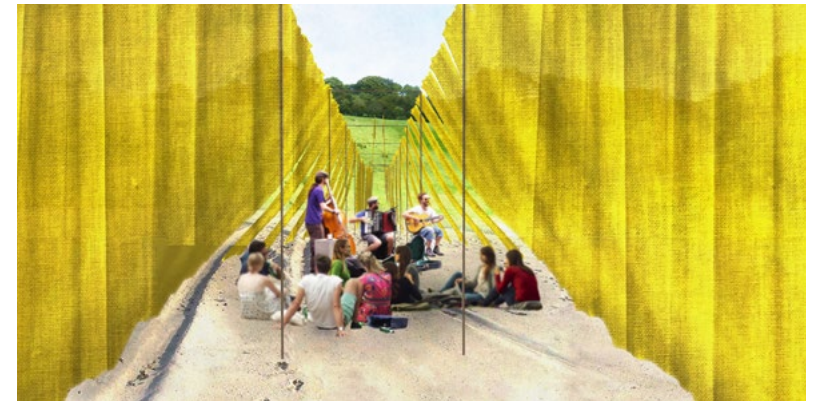

enhanced spaces for aliens

oversigt the concept of creating a piece of furniture suitable for any terrestrial or extraterrestrial creature.

kategori design&technology



express your cell

oversigt a meditation pavilion on the beach

kategori design&construction

material wood

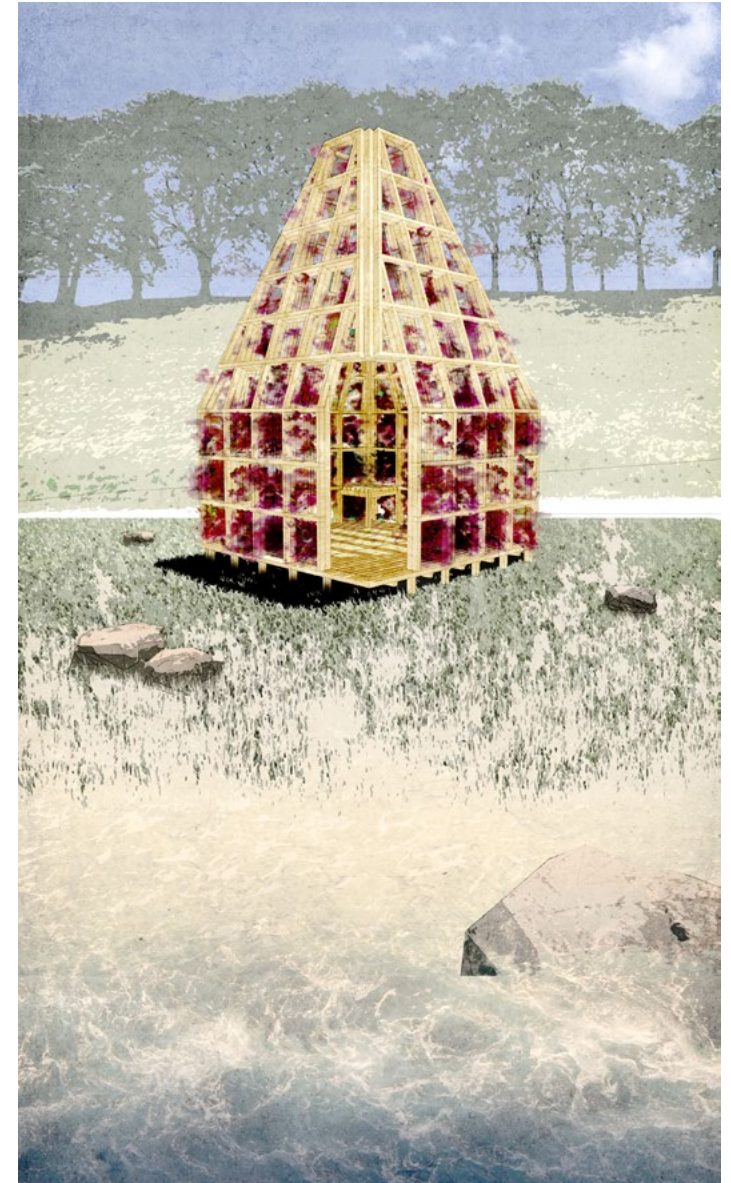
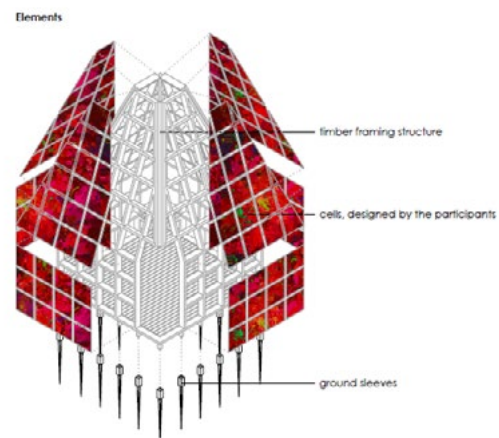
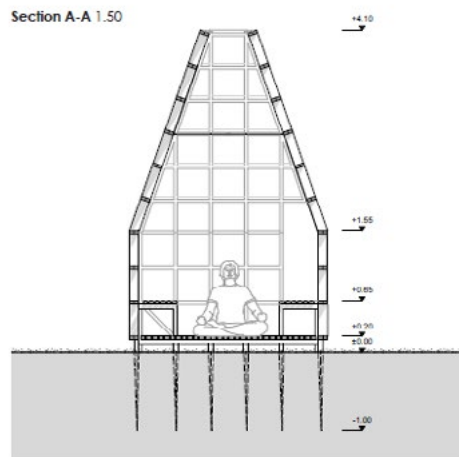

the unborn monuments

oversigt This monument of 3x3m can be conceived as a micro city replica of Fredericia, shaped by 70 models developed in plots of 30x10cm. Each participant will take responsibility for filling a specific number of the plots, and indirectly influence the final result.

kategori crafts

material gips

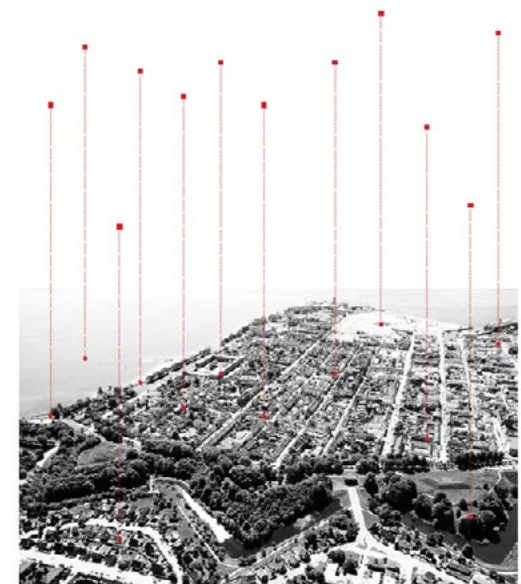
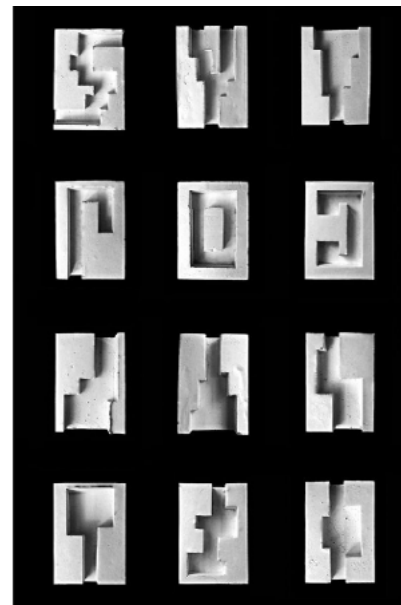
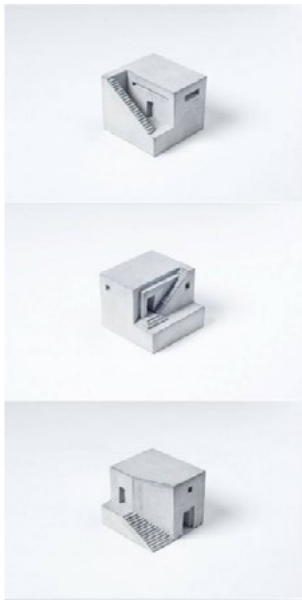
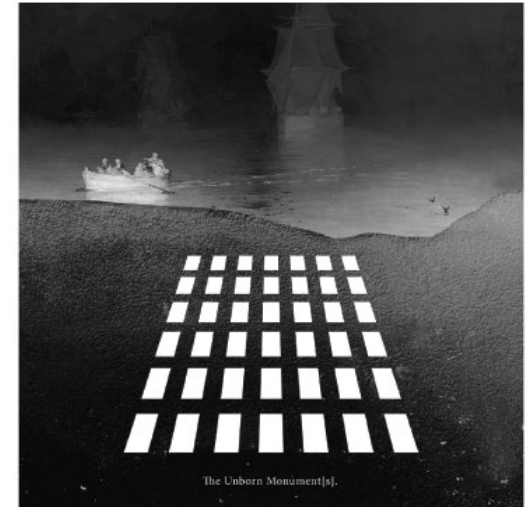



e

EASA
european architecture students assembly

HOSPITALITY

d

s

FREDERICIA
denmark 2017

u

finding the framework

vi ses snart!

